

Tightening instructions for adjustable pivot bolt

Attention:

Tighten only within the specified ride height range!
No paint residues between eccentric/thrust washer and hanger!

Check torque settings after the first 5000kms for steel hangers.
For aluminium and stainless steel hangers check the torque settings after 500KMS.
Do not reuse pivot bolt and nut.
Do not oil or grease threads.

Bolt head always on the eccentric washer side.

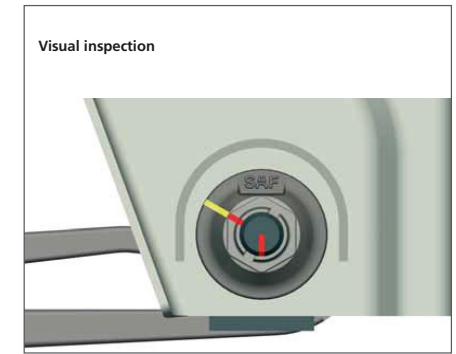
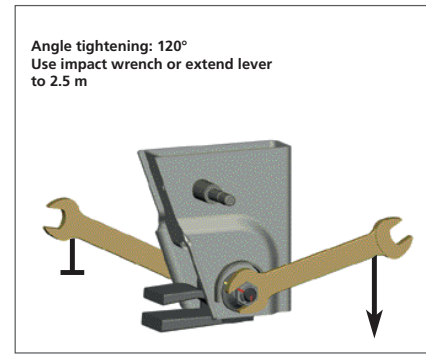
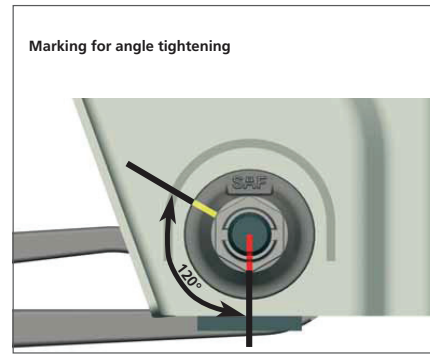
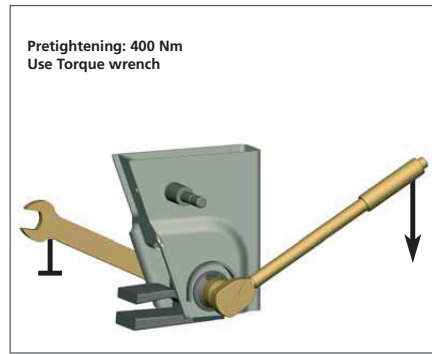
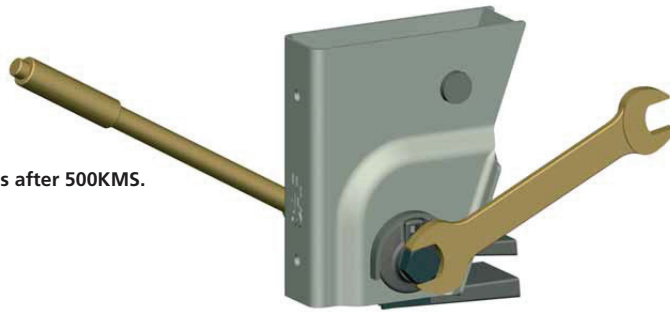

Tightening torques for SAF air suspension systems

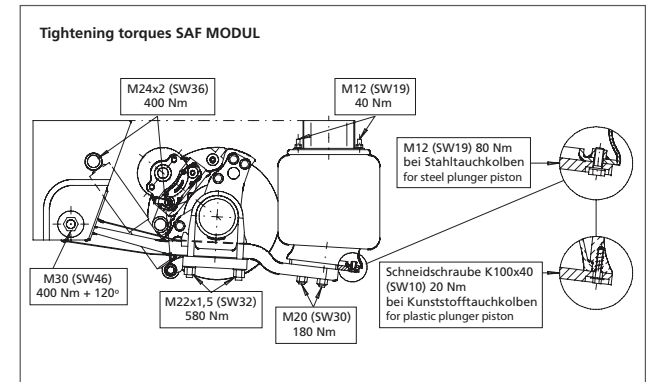
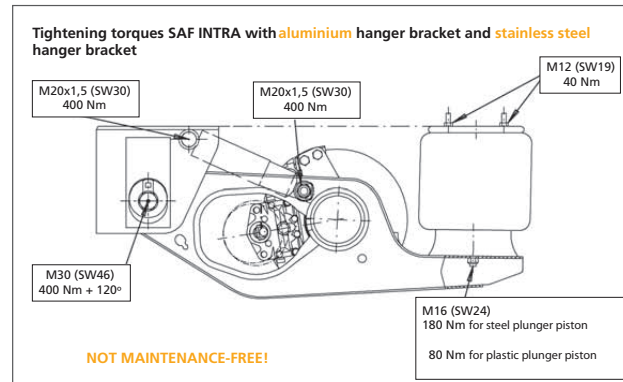
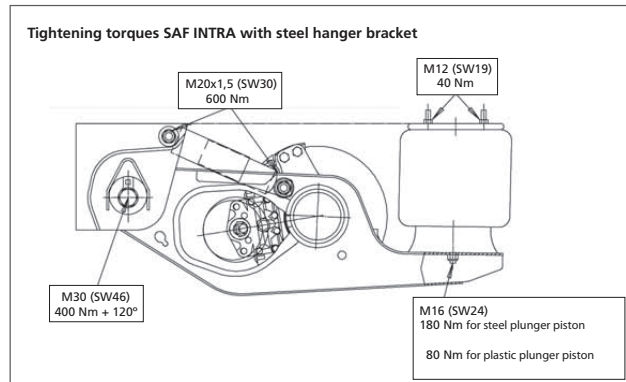

Attention!

- Pivot Bolt and Nut to be used only once.
- Threads not to be oiled or greased!
- Shock absorber nuts to be used only once.
- Service Intervals for Steel Hanger Brackets:
 - First check after 5000kms
 - Further checks every 12 months
- Service intervals for aluminium hanger brackets and stainless steel hanger brackets: first check after 500 km, further check after every 6 months
- Spring eye bolt: Inspection torque 1,200 Nm
Shock absorber bolt: Inspection torque 400 Nm

For transport productivity solutions, talk to the Gough Transpecs team:

TOLLFREE: 0800 875 669 | TRANSPECS.CO.NZ